

DESO

engineering

bunded tanks



diesel dispensers



single skin oil tanks



waste oil wells



ad blue tanks





DESOTO engineering



DESOTO is a world class rotational moulding company specialising in the design and production of liquid storage and dispensing containers. Tanks and bowlers are produced for fuel, chemical and water applications. Uniquely in the UK, DESOTO design and manufacture all moulding machines and tooling in house ensuring the highest technical standards. Our comprehensive range of products are distributed throughout the UK and Europe.

Our products comply with the latest European standards and provide cost effective solutions to domestic, commercial and agricultural storage and dispensing requirements. Bunded tanks have a 10 year guarantee (subject to conditions) and are supplied with moulded-in fittings and o-ring seals for unsurpassed protection against leaks. Manufactured from high grade polyethylene, DESOTO tanks are corrosion resistant, have high impact strength and UV stabilisation packages.

Index

3 - 5	Bunded Tanks
6 - 7	Diesel Dispensers
8	Single Skin Oil Tanks
9	AdBlue® Tanks
10	Waste Oil Wells
11	Sustainable Water and Energy

Installation Kit

optional accessories for the DESOTO oil tank range



Top Outlet Kit

The Environment Agency in their Pollution Prevention Guideline PPG2 prefer top outlet tanks and the guidelines specify anti-siphon valve to be installed. Contact us for more information.

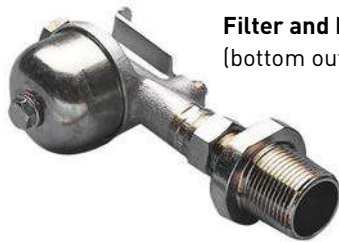

Filter and Isolating Valve
(bottom outlet only)



Remote Tank Monitoring

Watchman Tank Monitoring kit available, contact us for more information.

bunded tanks



V1230BT

a 1250mm **b** 1600mm
Max-Fill Capacity*:
 1172 Litres (258 gallons)
Tank Footprint: 1230mm
Weight: 96 kgs



V1340BT

a 1410mm **b** 1530mm
Max-Fill Capacity*:
 1301 Litres (286 gallons)
Tank Footprint: 1390mm
Weight: 107 kgs



V2455BT

a 1700mm **b** 1730mm
Max-Fill Capacity*:
 2326 Litres (512 gallons)
Tank Footprint: 1670mm
Weight: 155 kgs



V3500BT

a 2120mm **b** 1600mm
Max-Fill Capacity*:
 3478 Litres (765 gallons)
Tank Footprint: 2060mm
Weight: 195 kgs



V5000BT

a 2120mm **b** 2300mm
Max-Fill Capacity*:
 4955 Litres (1090 gallons)
Tank Footprint: 2060mm
Weight: 265 kgs

V9400BT

a 2510mm **b** 2800mm
Max-Fill Capacity*:
 8950 Litres (1969 gallons)
Tank Footprint: 2450mm
Weight: 390 kgs



Lifting eye
 on V9400BT
 (tank only to
 be lifted when
 empty)



*Dimensions may vary. Actual capacities may vary.

bunded tanks

SL650BT

a 1300mm b 1350mm

c 630mm

Max-Fill Capacity*:

668 Litres (147 gallons)

Tank Footprint: 605mm x 1170mm

Weight: 100 kgs



SL1000BT

a 1890mm b 1340mm

c 645mm

Max-Fill Capacity*:

1024 Litres (214 gallons)

Tank Footprint: 610mm x 1860mm

Weight: 125 kgs



SL1250BT

a 2000mm b 1660mm c 650mm

Max-Fill Capacity*:

1175 Litres (258 gallons)

Tank Footprint: 600mm x 1860mm

Weight: 145 kgs



SL1400BT

a 2140mm b 1695mm

c 660mm

Max-Fill Capacity*:

1371 Litres (302 gallons)

Tank Footprint: 630mm x 2100mm

Weight: 180 kgs





LP1200BT

- a 2000mm b 930mm
- c 1400mm

Max-Fill Capacity*:
1294 Litres (285 gallons)

Tank Footprint:
1230mm x 1890mm

Weight: 120 kgs



H1800BT

- a 1970mm b 1510mm
- c 1350mm

Max-Fill Capacity*:
1899 Litres (418 gallons)

Tank Footprint:
1190mm x 1710mm

Weight:
155 kgs



H1550BT

- a 2000mm
- b 1500mm
- c 950mm

Max-Fill Capacity*:
1490 Litres
(328 gallons)

Tank Footprint:
1740 x 860

Weight: 150 kgs

H2500BT

- a 2300mm
- b 1450mm
- c 1250mm

Max-Fill Capacity*:
2518 Litres
(554 gallons)

Tank Footprint:
2000mm x 1215mm

Weight: 190kgs



*dimensions may vary. Capacities may vary.

diesel dispensers

DESO supply a complete range of diesel dispensers which comply with the latest control of pollution regulations. Products range in capacity from 1340 litres to 9400 litres.

All models are supplied as standard with 10 micron water and particulate filters, 6m hose (excluding H1550 and H2500 which have 4m hose), automatic nozzles, overfill prevention device and contents gauging.

Different pump options are available; 12V, 110V and 230V*.

Diesel Management System, faster pump and hose reels* are optional extras if required on capacities between 3500-9400L.

*See specific models for available options



V1340DD

a 1420mm **b** 1740mm

Max-Fill Capacity*:
1301 Litres (286 gallons)
Tank Footprint: 1390mm
Weight: 130 kgs



V2350DD

a 1710mm
b 1900mm

Max-Fill Capacity*:
2326 Litres (512 gallons)
Tank Footprint: 1690mm
Weight: 170 kgs



V3500DD

a 1710mm **b** 1885mm

Max-Fill Capacity*:
3500 Litres (770 gallons)
Tank Footprint: 1660mm
Weight: 205 kgs



VLP5000DD**

a 2480mm **b** 2000mm

Max-Fill Capacity*:
4955 Litres (1090 gallons)
Tank Footprint: 2430mm
Weight: 300 kgs

**Faster pump and hose reel available as optional extra.

**diesel
dispensers
vertical**



H1550CDD

a 2000mm **b** 1500mm
c 950mm

Max-Fill Capacity*:
1490 Litres (328 gallons)
Tank Footprint: 1740x860
Weight: 135 kgs



H2500CDD

a 2300mm **b** 1450mm
c 1250mm

Max-Fill Capacity*:
2518 Litres (554 gallons)
Tank Footprint: 1980mm x 1200mm
Weight: 190kgs

V9400DD

The V9400DD model is supplied as standard with 6m 3/4" hose, integral digital flow meter, 10 micron particle and water filter, overfill prevention, bund alarm and digital level gauge. 230 availability only.

Also Available (Coming Soon):

- Watchman Access Management System
- Faster 100lpm pumps
- 8m Hose Reel

a 2480mm
(3150mm including POD)

b 2000mm

Max-Fill Capacity*:
9400 Litres (2067 gallons)

Tank Footprint: 2450mm
+ 400mm x 600mm for POD base

Weight: 460 kgs



*dimensions may vary. Capacities may vary.

single skin oil tanks

single skin oil tanks



V1340T

a 1250mm **b** 1440mm
Max-Fill Capacity*:
 1301 Litres (286 gallons)
Tank Footprint: 1250mm
Weight: 45 kgs



V2455T

a 1510mm **b** 1600mm
Max-Fill Capacity*:
 2326 Litres (512 gallons)
Tank Footprint: 1510mm
Weight: 65 kgs



LP1230T

a 1900mm **b** 860mm
c 1240mm
Max-Fill Capacity*:
 1289 Litres (284 gallons)
Tank Footprint: 1050mm x 1750mm
Weight: 55 kgs



H1235T

a 1770mm **b** 1120mm **c** 1030mm
Max-Fill Capacity*:
 1271 Litres (280 gallons)
Tank Footprint: 980mm x 1460mm
Weight: 55 kgs



R1220T

a 2060mm **b** 1120mm
c 660mm
Max-Fill Capacity*:
 1197 Litres (263 gallons)
Tank Footprint: 560mm x 1810mm
Weight: 75 kgs



H1900T

a 1850mm **b** 1340mm **c** 1240mm
Max-Fill Capacity*:
 1899 Litres (418 gallons)
Tank Footprint: 960mm x 1460mm
Weight: 65 kgs



H2500T

a 2400mm **b** 1320mm **c** 1250mm
Max-Fill Capacity*:
 2488 Litres (547 gallons)
Tank Footprint: 1160mm x 1940mm
Weight: 100 kgs

AdBlue™ tanks

DESO manufacture AdBlue® dispensing units which come complete with the following as standard:

- Stainless steel dry-break coupling
- Hose
- Nozzle
- Flow meter

V1340 Ad Blue

a 1420mm **b** 1740mm

Max-Fill Capacity*:

1301 Litres (286 gallons)

Tank Footprint: 1390mm

Weight: 125 kgs



V2350 Ad Blue

a 1710mm

b 1900mm

Max-Fill Capacity*:

2326 Litres

(512 gallons)

Tank Footprint: 1690mm

Weight: 180 kgs



V3500 Ad Blue

a 1885mm

b 1885mm

Max-Fill Capacity*:

3478 Litres

(765 gallons)

Tank Footprint: 1660mm

Weight: 205 kgs



VLP5000 Ad Blue

a 2480mm

b 2000mm

Max-Fill Capacity*:

4955 Litres

(1090 gallons)

Tank Footprint: 2430mm

Weight: 280 kgs



**waste oil
wells
& spill
containers**

Lockable easy access lid



DESO supply a complete range of waste oil wells (WOW) and spill containment products. Our WOW's comply with the latest control of pollution regulations and have the benefit of easy access lid and tondish.

Product Code	Capacity* (litres/gallons)	Length (mm)	Width (mm)	Height (mm)
H1235WOW	1224 / 269	2015	1230	1362
H1550WOW	1480 / 326	2000	950	1500
H1800WOW	1899 / 418	1970	1350	1510
H2500WOW	2518 / 554	2300	1250	1450
LP1200WOW	1289 / 284	2000	650	1660
SL1000WOW	973 / 214	1890	645	1340
SL1250WOW	1175 / 258	2140	660	1695
SL1400WOW	1371 / 302	2000	1400	930
SL650WOW	668 / 147	1300	630	1350
V1230WOW	1172 / 258	-	1250	1600
V1340WOW	1301 / 286	-	1410	1530
V2455WOW	2326 / 512	-	1700	1730
V3500WOW	3478 / 765	-	2120	1600
V5000WOW	5038 / 1108	-	2120	2300
V9400WOW	8950 / 1969	-	2800	2800

DESO
Engineering
part of

Kingspan
Water & Energy Ltd.

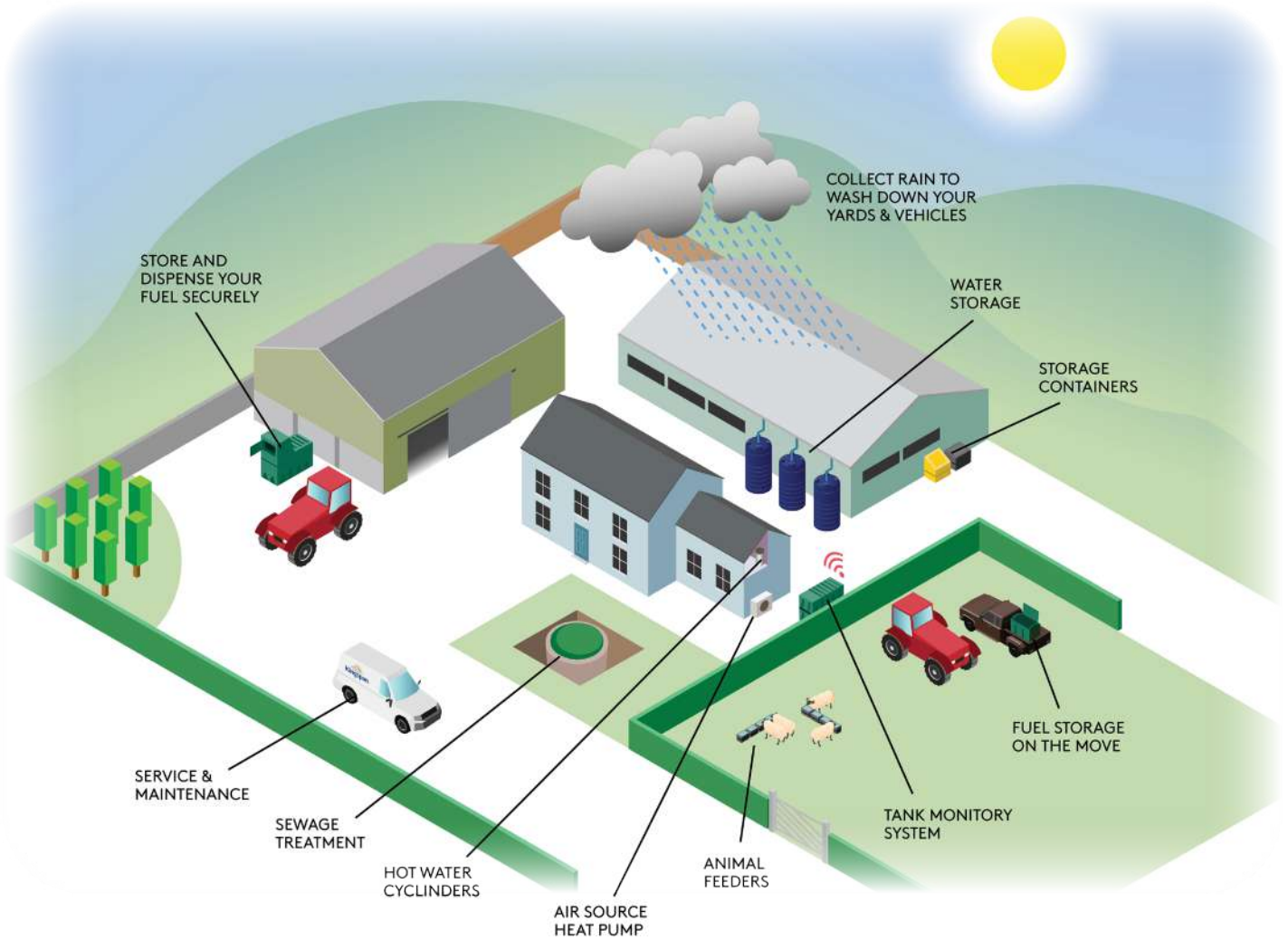

Notes

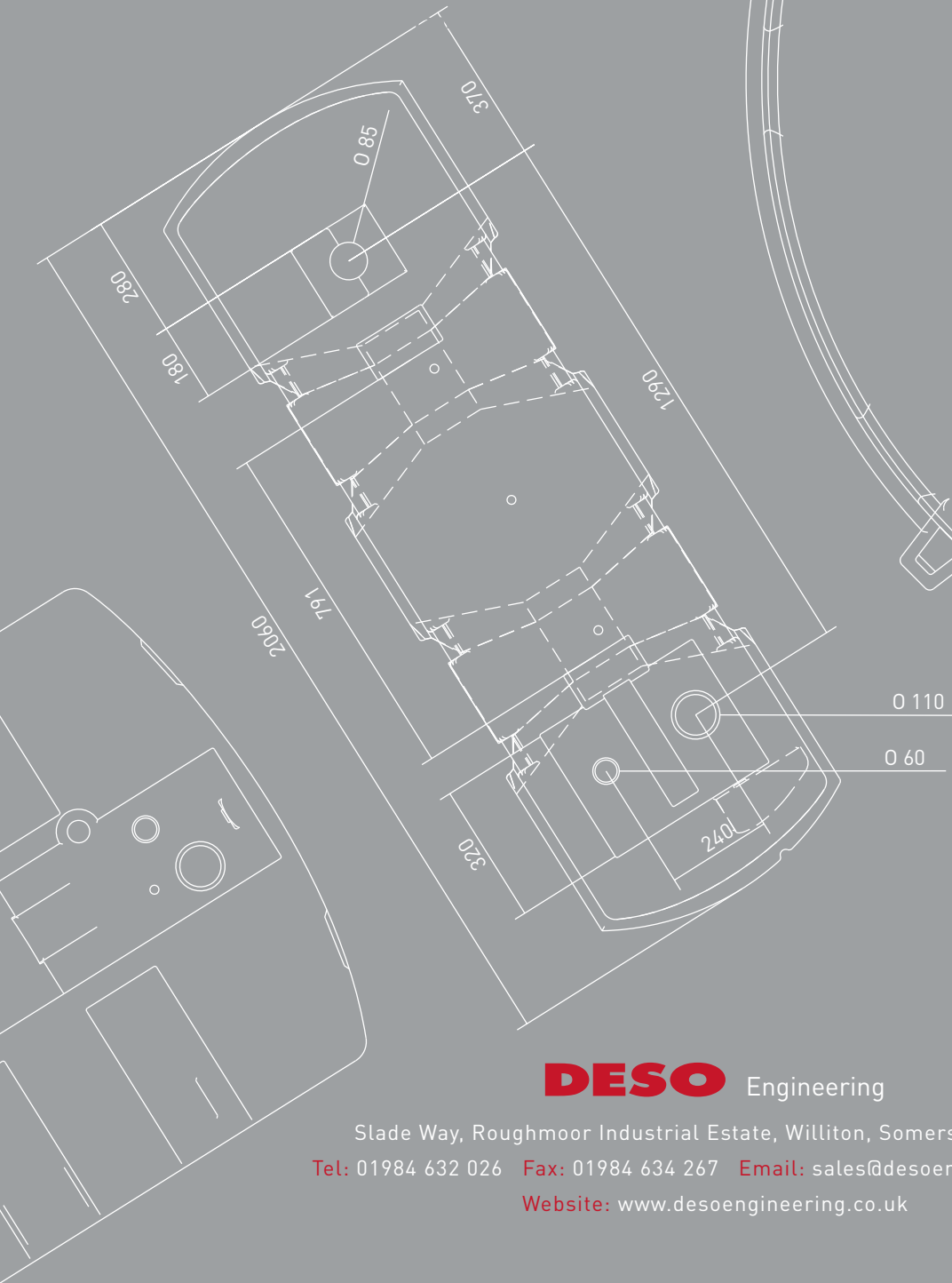
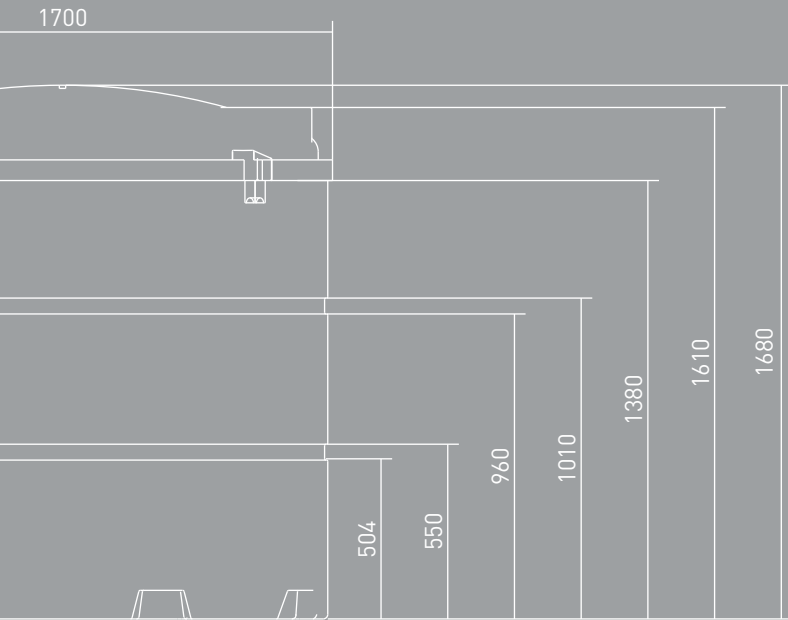

DESO Engineering

Slade Way, Roughmoor Industrial Estate, Williton, Somerset. TA4 4TB

Tel: 01984 632 026 Fax: 01984 634 267 Email: sales@desoengineering.co.uk

Website: www.desoengineering.co.uk